



**Microliter OEM
Pump Module
Users Manual**



Model #78-2900

Publication # 5611-003 Rev. E

WEEE/RoHS Compliance Statement

EU Directives WEEE and RoHS

To Our Valued Customers:

We are committed to being a good corporate citizen. As part of that commitment, we strive to maintain an environmentally conscious manufacturing operation. The European Union (EU) has enacted two Directives, the first on product recycling (Waste Electrical and Electronic Equipment, WEEE) and the second limiting the use of certain substances (Restriction on the use of Hazardous Substances, RoHS). Over time, these Directives will be implemented in the national laws of each EU Member State.

Once the final national regulations have been put into place, recycling will be offered for our products which are within the scope of the WEEE Directive. Products falling under the scope of the WEEE Directive available for sale after August 13, 2005 will be identified with a "wheelie bin" symbol.

Two Categories of products covered by the WEEE Directive are currently exempt from the RoHS Directive - Category 8, medical devices (with the exception of implanted or infected products) and Category 9, monitoring and control instruments. Most of our products fall into either Category 8 or 9 and are currently exempt from the RoHS Directive. We will continue to monitor the application of the RoHS Directive to its products and will comply with any changes as they apply.



- **Do Not Dispose Product with Municipal Waste**
 - **Special Collection/Disposal Required**

KDS Microliter OEM Module

Table of Contents

SUBJECT	PAGE NO.
General Information - Warranty and Repairs	4
General Safety Summary	5-6
Introduction:	
Theory of Operation	7
Features	7-8
Input Connections	8
Installation:	
Initial Setup & Location Requirements	9
Loading the Syringe	9
Operation:	
Getting Started	10
Working with the pump	10
Check Syringe	10
Maintenance	10
Protecting Small, Fragile Syringes	10
Hyper-Terminal	11-12
Appendices:	
A. Specifications	13-14
Inputs	14
Outputs	14
B. Table of Popular Syringe Diameters	5
C. Flow Rates	16
D. Serial Communications; Commands, Queries and Responses	17-18
E. Daisy Chaining	19
F. Packing List	20

KDS Microliter OEM Module

General Information

Serial Number

All inquires concerning our product should refer to the serial number of the unit. Serial numbers are located on the underside of the mounting plate.

Calibration

All syringe pumps are designed and manufactured to meet their performance specifications at all rated voltages and frequencies.

Warranty

KD Scientific warranties this instrument for a period of one year from date of purchase. At its option, KD Scientific will repair or replace the unit if it is found to be defective as to workmanship or material.

This warranty does not extend to damage resulting from misuse, neglect or abuse, normal wear and tear, or accident.

This warranty extends only to the original customer purchaser.

IN NO EVENT SHALL KD SCIENTIFIC BE LIABLE FOR INCIDENTAL OR CONSEQUENTIAL DAMAGES. Some states do not allow exclusion or limitation of incidental or consequential damages so the above limitation or exclusion may not apply to you. **THERE ARE NO IMPLIED WARRANTIES OF MERCHANTABILITY, FITNESS FOR A PARTICULAR USE, OR OF ANY OTHER NATURE.** Some states do not allow this limitation on an implied warranty, so the above limitation may not apply to you.

If a defect arises within the warranty period, promptly contact KD Scientific: 84 October Hill Road, Holliston, Massachusetts 01746-1388 or call 508-429-6809. Goods will not be accepted for return unless an RMA (returned materials authorization) number has been issued by our customer service department. The customer is responsible for shipping charges. Please allow a reasonable period of time for completion of repairs, replacement and return. If the unit is replaced, the replacement unit is covered only for the remainder of the original warranty period dating from the purchase of the original device.

This warranty gives you specific rights, and you may also have other rights which vary from state to state.

Repair Facilities and Parts

KD Scientific stocks replacement and repair parts. When ordering, please describe parts as completely as possible, preferably using our part numbers. If practical, enclose a sample or drawing. We offer a complete reconditioning service.

CAUTION:

This pump is not registered with the FDA and is not for clinical use on human or veterinary patients. It is intended for research use only

<p>CAUTION NOT FOR CLINICAL USE ON HUMAN PATIENTS</p>
--

KDS Microliter OEM Module

General Safety Summary

Please read the following safety precautions to ensure proper use of your modular syringe pump. To avoid potential hazards and product damage, use this product only as instructed in this manual. **If the equipment is used in a manner not specified by the manufacturer, the protection provided by the equipment may be impaired.**

TO PREVENT HAZARD OR INJURY:

Use Appropriate Power Supply

Use only an approved power supply. Be sure to observe proper polarity of connections when hooking up DC supply voltage.

CAUTION: FAILURE TO MAINTAIN POLARITY MAY RESULT IN DAMAGE TO THE UNIT AND WILL VOID THE WARRANTY.

12-30Vdc positive-PIN 1 on Pin Header (P8)

12-30Vdc return-PIN 2 on Pin Header (P8)

Ground the Product

This product is grounded through a ground stud located on the under side of the base plate. To avoid electric shock, the grounding conductor must be connected to earth ground. Before making any connections to the input or output terminals of the product, ensure that the product is properly grounded.

Make Proper Connections

Make sure all connections are made properly and securely. Any signal wire connections to the unit must be no longer than 3 meters.

Orient Equipment Properly

Do not position the equipment such that it is difficult to reach the disconnecting device.

Observe all Terminal Ratings

Review the operating manual to learn the ratings on all connections.

Avoid Exposed Circuitry

Do not touch any electronic circuitry inside of the product.

Do Not Operate with Suspected Failures

If damage is suspected on or to the product do not operate the product. Contact qualified service personnel to perform inspection.

Avoid Pinch Hazards

Pinch hazards may exist between the pusher block and the end block. Avoid placing fingers between these points while the pump is running.

Procedures which could result in injury shall only be carried out by operators who have been warned of the potential hazards and have received adequate training in carrying out the procedures in the safest possible manner.

KDS Microliter OEM Module

General Safety Summary (continued)

PLACE PRODUCT IN PROPER ENVIRONMENT

Environmental Conditions:

- Indoor use only
- Temperature 5 °C to 40 °C (40 °F to 104 °F)
- Humidity 20% to 80% RH
- Well Ventilated Room
- Altitude up to 2000 m
- DC Voltage Fluctuation not to Exceed +/- 5% of Nominal
- Transient Over voltage Category II
- Pump is Rated Pollution Degree I

OBSERVE ALL WARNING LABELS ON PRODUCT

Read all labels on product to ensure proper usage.



CAUTION

Refer to Manual



Protective Ground

Terminal



CAUTION

Pinch Hazard



CAUTION

ESD Sensitive Device



CAUTION

Pinch Hazard

KDS Microliter OEM Module

Introduction

THEORY OF OPERATION:

The μl OEM Pump Module is designed as a highly precise, single-syringe infusion/withdrawal pump module capable of low back pressure. The module includes a mechanism, hardware, power supply and user interface cable. There is no keypad or display available for this module, it must interface with a computer.

Typically, the μl OEM Pump Module holds one syringe of most makes, from 0.5 μl to 1 ml. The diameter of the syringe is entered via your PC or other controller, and the internal micro-processor drives a precision stepper motor to produce accurate fluid flow. This unit is designed to operate inside an appropriately rated fire/electrical/mechanical enclosure or cabinet.

FEATURES

Volume

A target volume can be entered for infusion and refill independently, and the pump automatically stops when this volume is reached. The pump displays an initial volume of zero and increases as the dispense proceeds to the target volume. The target volume can be reviewed or changed as the pump continues to operate.

Modes of Operation

Infusion

- Rate and volume settings: pump infuses to the set volume and stops.
- Rate setting only: pump runs until manually stopped, limit switches are hit, or stalls.

Withdrawal

- Rate and volume settings similar to above.

Infusion/withdrawal

- Infusion automatically followed by withdrawal. Rate and volume settings can be made independently for infusion and withdrawal, hence the pump can infuse at one rate and volume and then change to a different withdrawal flow rate and volume setting.

Withdrawal/infusion

- Withdrawal immediately followed by infusion. Separate settings for rate and volume can be made for withdrawal and infusion.
- Continuous operation
- The pump cycles from infusion to withdrawal continuously. The volume is identical in infuse and withdrawal directions.

INFUSE and WITHDRAW LIMIT SWITCHES

An infuse limit switch is located on the syringe block and an adjustable actuator is located on the pusher block. When the pusher block actuator contacts the limit switch, infusing is stopped. Adjust the actuator appropriately such that the syringe plunger does not bottom out in the syringe barrel.

The withdraw limit switch is located in the pulley cover, which is connected to a movable guide rod. The guide rod is equipped with an adjustable clamp collar. When the pusher block comes in contact with the adjustable clamp collar, the withdraw limit switch is actuated and pusher block movement is halted. Adjust the clamp collar appropriately such that the syringe plunger does not pull out of the syringe barrel.

KDS Microliter OEM Module

Introduction (continued)

STALL DETECTION

The motor is monitored by an optical encoder to confirm the programmed movement. If the back pressure increases due to jamming or flow restriction, then the motor may stall. Stall detection by the encoder results in a pump shutdown.

NON-VOLATILE MEMORY

All operational settings are stored in non-volatile memory for convenience, and are used to set the pump when first powered on.

SELECTION OF RATE AND VOLUME UNITS

Units of volume (μ or ml) and flow rate (μ /ml per min/hr) can be changed if required.

Input Connections

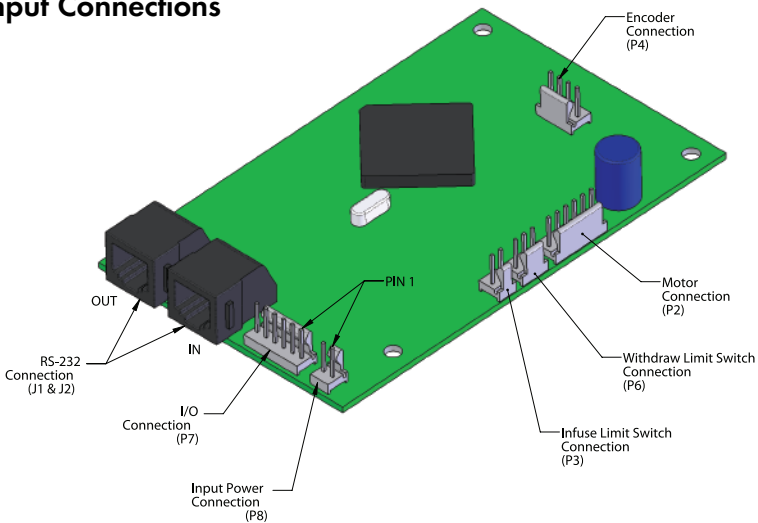

Pin-outs

Input Power	Power	P8-1
Connection	Return	P8-2
Digital I/O	Run IND	P7-1
Connection	VCC	P7-2
	EXT ENABLE	P7-3
	Ground	P7-4
	Run/Stop	P7-5
	Ground	P7-6

KDS Microliter OEM Module

Installation

LOCATION REQUIREMENTS FOR THE SYRINGE PUMP

- A sturdy, level, clean and dry surface
- Minimum of one inch (2.5cm) clearance around the pump
- Appropriate environmental conditions
- Mount into an appropriately rated enclosure or cabinet
- Required clearance below mounting panel: 2.00" (5cm).

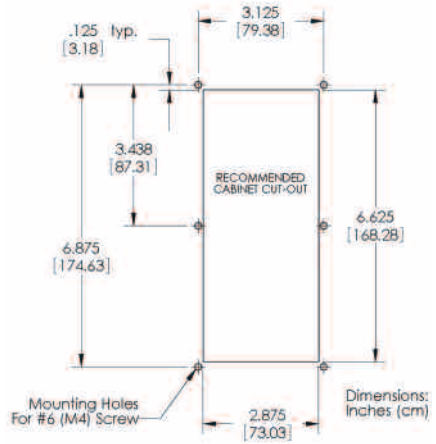

LOADING THE SYRINGE

1. Release the syringe pusher (4) by pressing the bronze button (3) on the side of the pusher.
2. While holding the bronze button 'in', slide the pusher to the right.
3. Raise the spring loaded syringe retainer (1) and swing it out of the way.
4. Lay the loaded syringe in the 'V' shaped holder.
5. Swing the retainer so it holds the syringe in place.
6. Move the pusher so it makes contact with the syringe plunger.
7. Adjust pusher block thumbscrews & bracket (2) until the Syringe plunger is completely captured.
8. The limit switches can be easily adjusted by loosening the #2 nuts (not shown), sliding the switch to the desired position, and retightening the nuts into place.

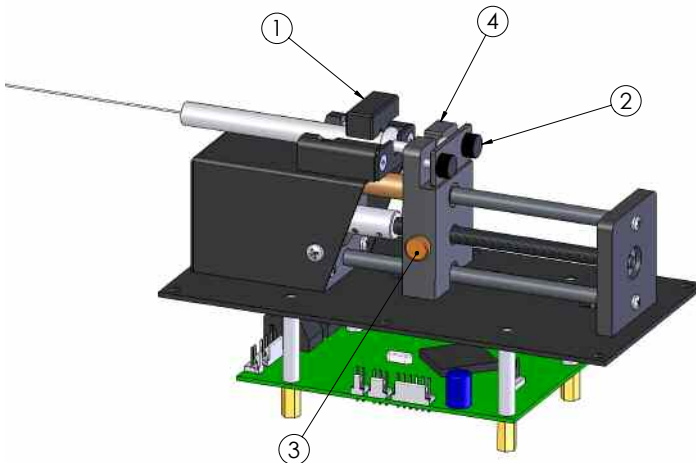

KDS Microliter OEM Module

Operation

GETTING STARTED

Plug one end of the power cable into P8 connection on board. Connect communication cable from PC to J1 connector. Refer to page 6 of this manual to reference the board connections.

WORKING WITH THE PUMP

The safest way to use the “ μL ” OEM Pump Module is in the volume dispense mode. The pump will automatically stop when target volume is dispensed.

Enable must be tied to ground (Hardwire P7-3 to P7-4 or connect through switch).

CHECK SYRINGE OFTEN

The “ μL ” OEM Pump Module will shut itself off when the syringe is empty or is otherwise overloaded. Although this presents no hazard to the user or the pump, it is prudent to check the syringe from time to time.

MAINTENANCE

Keep the “ μL ” OEM Pump Module clean and dry. Avoid liquid spills that may find their way into the electronics.

A small tube of grease is provided for periodic lubrication of the lead screw. It is important to keep the lead screw clean and lubricated.

To clean the exterior surfaces above the base plate, use a lint-free cloth to remove loose dust. For more efficient cleaning, use a soft cloth dampened with water or an aqueous solution of 75% isopropyl alcohol.

If the pump does not work properly, contact KD Scientific for appropriate instructions.

PROTECTING SMALL, FRAGILE SYRINGES

The “ μL ” OEM Pump Module will hold micro liter size syringes down to 0.5 μL size. These small syringes have fine wire plungers that may be damaged if allowed to bottom out. The limit switches for the “ μL ” OEM Pump Module can be adjusted by loosening the mounting hardware which attaches the switch to the base plate bracket, moving the switch to the desired location, and re-tightening the switch mounting hardware.

KDS Microliter OEM Module

HYPER-TERMINAL: Terminal Emulation Software

REMOTE CONTROL VIA THE RS-232 INTERFACE USING HYPERTERMINAL*

* Normally included with most Windows® operating systems.

Milliliter Modular Syringe Pump Component

1. Connect the RS-232 cable between the “ μ L” OEM Pump Module RS-232 IN port and a PC’s serial port.
2. On the PC (running a Microsoft Windows Operating System), select START – PROGRAMS – ACCESSORIES – HYPERTERMINAL – HYPERTERMINAL to start the HyperTerminal application. If HyperTerminal is not available, install it from the Microsoft Windows Operating System Install disks or CD ROM.
3. Set up the appropriate COMPORT for the following:

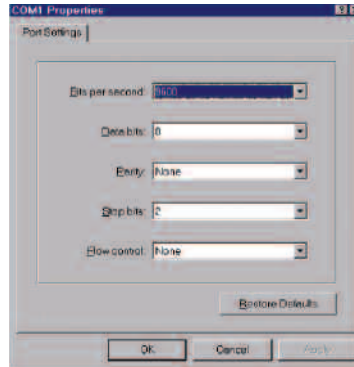
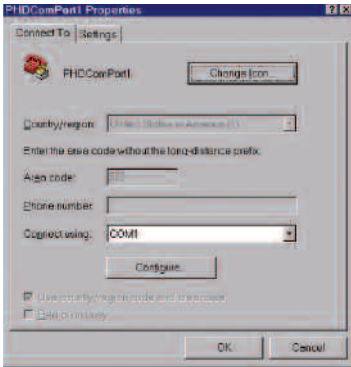

Configure:

Baud Rate: 9600
Data Bits: 8
Parity: None
Stop Bits: 2
Flow Cntrl: None
Emulation: Auto Detect

ASCII Setup:

Echo typed characters locally
Line delay: 0
Character delay: 0
Wrap lines

KDS Microliter OEM Module

HYPER-TERMINAL: Terminal Emulation Software (continued)

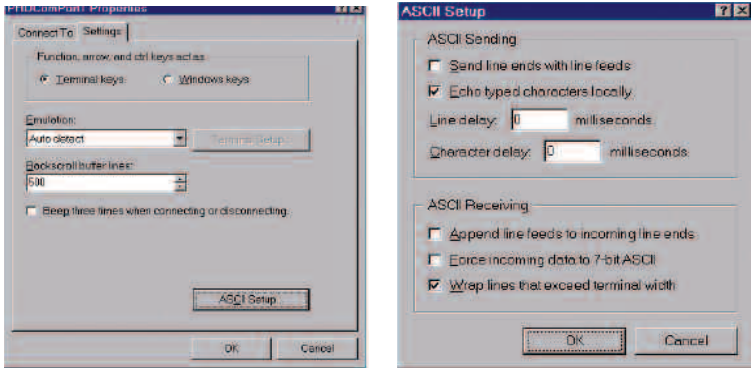

You may want to save the setup information under a descriptive filename.

4. At the PC, launch HyperTerminal with the above setup specifications (if it is not already running). Type PROM? at the PC keyboard and verify that the pump module's version is displayed at the PC terminal.
5. Type RUN to start the pump; type STOP to stop the pump. After starting the pump, > should be displayed, indicating pump is infusing. After stopping the pump, : should be displayed.

KDS Microliter OEM Module

Appendix A: Specifications

Accuracy	±0.35%
Reproducibility	±0.1%
Number of Syringes	One
Syringe Sizes	0.5µL (min), 1 mL (max)
Flow Rate:	
Minimum	0.001 µL/hr (0.5µl syringe)
Maximum	1.330 mL/min (1ml syringe)
Linear Force	7lbs (peak min.) Adjustable
Drive	Motor: 0.9° Stepper
Control	Constant Current Drive, 0.50A peak per phase 1/4 & 1/16 micro stepping
Drive Ratio	1:1
Leadscrew Pitch	48 threads per inch (1/4-48)
Encoder	Optical, 100 line (for stall detection)
Step Rate:	
Minimum	3.8 sec/step
Maximum	50 µsec/step
Pusher Travel Rate:	
Minimum	0.001 mm/min
Maximum	83.4mm/min
Display	None
Keypad	None
Interface	RS-232
Connectors	Power: 2 -pin Header, .1 centers RS-232: RJ-11 Phone jack
Power	+12 to +30VDC +/- 5%, 12W max.
Dimensions	7.25" X 3.625" X 4.50" (L X W X H) 18.41cm X 9.20cm X 11.43cm
Mounting Dimensions	6.875" X 3.25" (Mounting holes for (6) #6 screws) 17.46cm X 8.25cm
Ground Stud	#6-32 Stud
Weight	1.8 lbs (0.8kg)
Environmental Operating:	
Temp	+5 to +40°C (natural convection cooling)
Humidity	20% to 80% RH non-condensing
Storage:	
Temp	-30 to +45°C
Humidity	10% to 90% RH non-condensing
Pollution Degree	Class I
Compliance	Lead Free, RoHS Compliant
Syringe Sizes	0.5µL (min), 1ml (max)

KDS Microliter OEM Module

The pump is set to the following default parameters on power-up and after an external enable command.

DEFAULT SETTINGS

Syringe Diameter:	2.300 mm
Rate:	3.000 ul/min
Range:	ul/min
Force:	100%
Address:	00
Baud Rate:	9600

I/O Specifications: Inputs

INPUTS

RUN/STOP

This is an active low, TTL level input, pulled up to +5V through a 10K ohm resistor. It is ESD protected through a TVS device and filtered with a 0.1uF capacitor to ground. Each pulse to a logic low toggles the pump between the RUN and STOP states.

EXT_ENABL/

This is an active low, TTL level input, pulled up to +5V through a 10K ohm resistor. It is ESD protected through a TVS device and filtered with a 0.1uF capacitor to ground. A transition from logic high to logic low causes the processor to reset to its default state and enables the motor drive. A transition from logic low to logic high disables the motor drive through hardware (independent of firmware). This input may be used for an emergency stop function.

****To enable pump, the unit or connector P7 pin 3, must be connected to ground****

Outputs

RUN_IND/

This is an active low output driven by two 74HCT14 inverters in parallel. An on-board resistor may be placed in series with this output to provide current limiting. The default resistor value is zero ohms. A logic low indicates RUN. A logic high indicates STOP.

INDICATORS

Power-on LED

When illuminated, indicates that board is powered on and +5VDC supply is operating.

RUN LED

When illuminated, indicates that pump is running. When extinguished, indicates pump is stopped.

KDS Microliter OEM Module

Appendix B: Syringe Inside Diameter

Unimetrics Series 4000 & 5000

Size	Diameter
10 µl	0.46 mm
25	0.729
50	1.031
100	1.460
250	2.300
500	3.260
1000	4.610

SGE Scientific Glass Engineering

Size	Diameter
25 µl	0.73 mm
50	1.03
100	1.46
250	2.30
500	3.26
1 ml	4.61

Hamilton–Microliter Series Gastight

Size	Diameter
.5 µl	0.103 mm
1	0.1457
2	0.206
5	0.3257
10	0.460
25	0.729
50	1.031
100	1.46
250	2.3
500	3.26
1 mL	4.61

KDS Microliter OEM Module

Appendix C: Flow Rates

nominal syringe size	nominal diameter (mm)	ul/hr		ul/min		ml/hr		ml/min	
		min	max	min	max	min	max	min	max
0.5 μ	0.103	0.001	39.840	0.001	0.664	0.001	0.040	0.000	0.000
1 μ	0.150	0.002	84.480	0.001	1.408	0.001	0.085	0.000	0.001
2 μ	0.210	0.003	165.601	0.001	2.760	0.001	0.166	0.001	0.003
5 μ	0.330	0.007	408.962	0.001	6.816	0.001	0.409	0.001	0.007
10 μ	0.460	0.013	794.581	0.001	13.243	0.001	0.795	0.001	0.013
25 μ	0.730	0.033	1999.999	0.001	33.352	0.001	2.001	0.001	0.033
50 μ	1.030	0.066	1999.999	0.001	66.397	0.001	3.984	0.001	0.066
100 μ	1.460	0.131	1999.999	0.002	133.407	0.001	8.004	0.001	0.133
250 μ	2.300	0.325	1999.999	0.005	331.077	0.001	19.864	0.001	0.331
500 μ	3.260	0.653	1999.999	0.012	665.133	0.001	39.907	0.001	0.665
1 ml	4.610	1.306	1999.999	0.022	1330.073	0.001	79.804	0.001	1.330

KDS Microliter OEM Module

Appendix D: Serial Communication

COMMANDS, QUERIES AND RESPONSES

After each transmission to the pump terminating with a CR character (ASCII 13), the pump enters remote mode and responds with the character sequence:

CR LF PROMPT

The prompt characters indicate the status of the pump as follows:

prompt	meaning	ASCII code
:	Stopped	(ASCII 58 decimal)
>	Running forward	(ASCII 62 decimal)
<	Running reverse	(ASCII 60 decimal)
*	Stalled	(ASCII 42 decimal)
*I	Infuse Limit switch actuated	(ASCII 42 decimal + ASCII 73 decimal)
*W	Withdraw Limit Switch actuated	(ASCII 42 decimal + ASCII 87 decimal)
*D	Disabled by emergency stop	(ASCII 42 decimal + ASCII 68 decimal)
*T	Target volume reached	(ASCII 42 decimal + ASCII 84 decimal)

Serial commands and their meanings:

COMMANDS:

run	Start running to present settings
stop	Stop motor
dir rev	Reverses pumping direction
clv	Clears volume accumulator to zero (Infuse Direction)
clvw	Clears volume accumulator to zero (Withdraw Direction)
clt	Clears target volume to zero (Infuse direction)
cltw	Clears target volume to zero (withdraw direction)
mode i	Sets Mode to infuse
mode w	Sets Mode to withdraw
mode i/w	Sets Mode to infuse/withdraw
mode w/i	Sets Mode to withdraw/infuse
mode con	Sets Mode to continuous

COMMANDS WITH NUMBERS (must have space before number):

dia nn.nn	Set syringe diameter in mm. n = 0 to 9
ratei nnnnn	Set infusion rate
u/u	nnnnn is 0 to 9 and u/u is units

KDS Microliter OEM Module

Appendix D: Serial Communication

ratew nnnnn u/u	Set withdrawal rate
voli nnnnn uu	Set infusion target volume nnnnn is 0 to 9 and uu is units
volw nnnnn u/u	Set withdrawal target volume
for p	Force setting as percentage p is 0 to 100

QUERIES:

prom?	queries the software versiona
run?	run status
dia?	present diameter setting
ratei?	infusion rate
ratew?	withdrawal rate
del?	delivered volume
voli?	infusion target volume
volw?	withdrawal target volume
dir?	current pumping direction
mode?	current mode
frc?	force setting as a percent

QUERIES WITH STRING RESPONSE:

LIM	Returns "infuse", "withdraw", or "False"; indicating limit switchactuation status.
EMG	Returns emergency stop input status (True/False); True = Emergency Stop

ERROR MESSAGES:

CR Lf E	Unrecognized command
CR Lf OOR	Entered value is out of range

KDS Microliter OEM Module

Appendix D: Serial Communication

***Note: Adjustable force settings

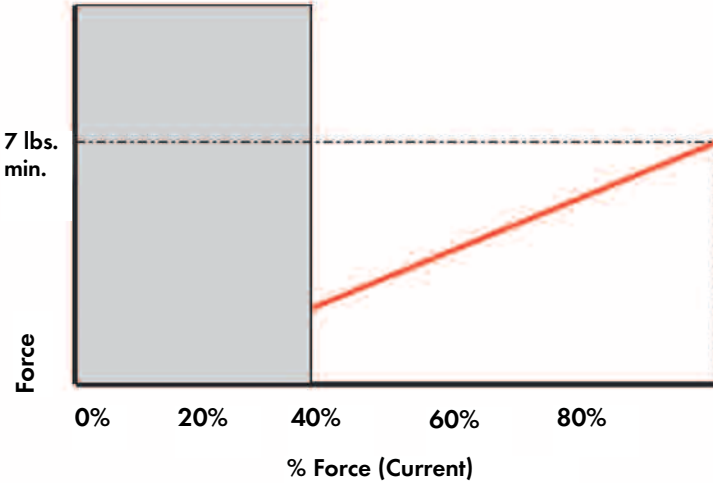

Due to differences in mechanical drag forces, we do not recommend operating the pump below 40% force level.

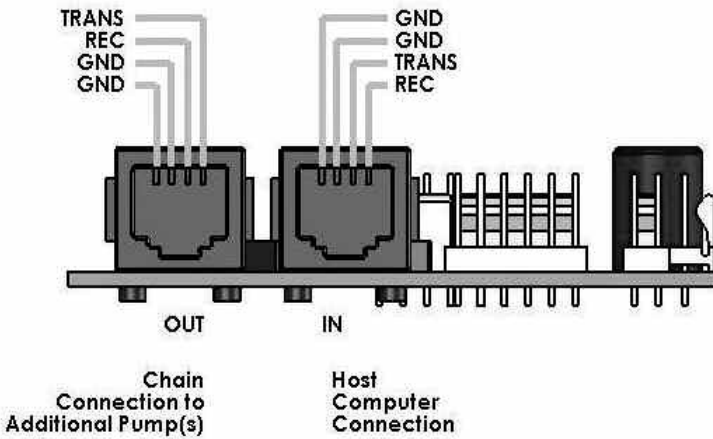

KDS Microliter OEM Module

Appendix E: Optional – Daisy-Chaining

The RS-232 Connection to the first board in the daisy-chain is made through the 9-pin D-Sub connector or RJ-11 input (J1). Use an appropriate adapter to connect a 9-pin or 25-pin D-Sub at a PC to the RJ-11 input. A straight-through RJ-11 to RJ-11 cable is used to connect from the RJ-11 output (J2) of the first board to the input of the next board in the daisy-chain. Set each board in the chain to be at a unique address (00 to 15) by setting the DIP switches (SW1) as follows:

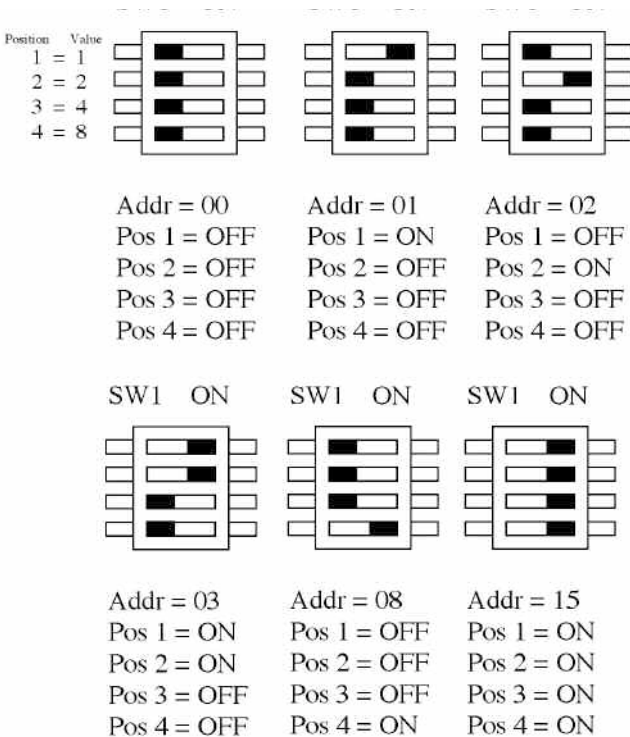

Fig. 1 - 5 Examples of the 16 Possible Address Configuration Settings

To communicate with each board in the daisy-chain, prefix commands and queries with the address. Addresses must be two digits (i.e. 00 to 15). These addresses are based on the principle of binary notation. Add up your address value by moving the appropriate switch to the "on" position.

****Pump must be power-cycled or reset for address change to be recognized.****

KDS Microliter OEM Module

Appendix F: Packing List and Optional Accessories

PACKING LIST

- 1) Main Unit
- 2) Universal input 100/250 VAC, 50/60 Hz, 18 watt power supply
- 3) Line Cord
- 4) Pump-to-power adapter cable
- 5) RS-232 Communications cable
- 6) User documentation
- 7) I/O & E-stop Cable w/ LED
- 8) 6 oz. tube of grease

Declaration of Conformity

In Accordance with ISO/IEC Guide 22 and EN 45014

Manufacturer: *KD Scientific Inc.*
84 October Hill Rd.
Holliston, MA 01746-1388
U.S.A.Phone: (508) 429-6809

We herewith declare that the following product:

Product Name: *Microliter OEM Pump Module*
Model No.: *78-2900*

To which this declaration relates, is in conformity with the applicable EC Directives, harmonized standards, and other normative requirements:

Application of
Council Directive(s): *89/336/EEC*

Standard(s) to which
Conformity is Declared:

Emissions/Immunity: *EN 61326-1:2005*
EN 61000-4-2
EN 61000-4-3
EN 61000-4-4
EN 61000-4-5
EN 61000-4-6
EN 61000-4-11
CISPR 11:2004 Class A

EMC and Safety compliance were evaluated by Intertek/ETL Semko
Reference test report file numbers: 3125838LTT-001 and 3125828LTT-003

(Signature)

06/28/07

(Date)

Beth Bauman

(Full Name)

VP Engineering / Operations

(Position)

